

Teamcenter 11.6 lifecycle visualization

Release Notes

010221540

Contents

Release Notes introduction	1-1
Lifecycle Visualization products	2-1
Deprecated platform announcement	3-1
What's new	4-1
What's new overview	4-1
New features for Base	4-1
Highlight model views for selected PMI	4-1
Background geometry is not cross-sectioned	4-1
Product views reflect structure changes	4-1
New features for Standard	4-2
View properties of 4GD partitions	4-2
New features for Professional	4-2
Immersive mode enhancements	4-2
New features for Mockup	4-3
Path generation improvements	4-3
Clearance analysis enhancements for 4GD objects	4-3
Clearance results preferences enhancements	4-4
Enhancements to clearance element pair analysis	4-5
New features for Variation Analysis	4-7
Point Measurement Generator enhancements	4-7
Optionally specifying datum gage diameter	4-8
Automated DPV Lite data linking	4-10
Automated feature naming	4-11
Supported platforms and locales	5-1
Supported platforms	5-1
Supported locales	5-1
System requirements	6-1
General system requirements	6-1
License server requirements	6-1
Teamcenter community collaboration visual conferencing requirements	6-1
Graphics hardware requirements	6-2
Help requirements	6-3
PDF requirements	6-4
IDW requirements	6-5
ADAMS conversion requirements	6-5
Visualization Illustration requirements	6-5
Convert and Print requirements	6-6

ClearanceDB requirements 6-6
Interoperability with other software 6-6
Teamcenter client communication system (TCCS) requirements 6-6

Resolved Problem Reports 7-1

Issues and workarounds 8-1

Supported file formats 9-1

Global Technical Access Center (GTAC) 10-1

Chapter 1: Release Notes introduction

These Release Notes summarize the changes made for Teamcenter 11.6 lifecycle visualization, encompassing all of the stand-alone Lifecycle Visualization products.

Chapter 2: Lifecycle Visualization products

Teamcenter lifecycle visualization is available in multiple product configurations, some of which also support optional software modules.

Note

For the latest information on optional modules, licensing requirements, and pricing, see your Siemens PLM sales representative.

For more information about system hardware and software requirements, see the [hardware and software certifications](#) page on GTAC.

<http://www.plm.automation.siemens.com/locale/support/gtac/certifications.shtml>

Base

Base is the entry-level viewer product configuration in the Lifecycle Visualization family of products. Providing powerful 2D viewing and markup capabilities along with basic 3D viewing functionality, Base is an ideal solution for the visualization of the many 2D and 3D file formats supported.

Features provided by Base include:

- Access to more than 40 2D file types
- A rich set of 2D navigation tools (pan, zoom, page changing, etc.)
- 2D adjust
- 2D markups and 2D GD&T markups
- 2D measurements
- 2D comparisons
- 2D printing
- 2D image capture
- 2D Snapshots
- Option to save and load session files containing 2D and 3D content
- Option to open and save .plmxml files
- .jt file support
- Direct read of Solid Edge and NX formats

- Visualize 4GD worksets
- 3D viewing
- 3D navigation tools (pan, zoom, rotate, fit all, zoom area, and seek)
- Standard views (view only)
- Basic support for product structure
- Basic 3D properties viewing
- Product and Manufacturing Information (PMI) viewing
- Basic 3D cross section functionality
- Basic 3D markup and 3D GD&T markup functionality (view only)
- Basic 3D measurement functionality (single and double only)
- Quick Pick, Smart Pick, and selection preview when selecting part features
- Basic 3D printing
- 3D Snapshots
- Ability to export images to popular formats (.jpg, .png, .bmp, .tiff, .hpgl, and more)
- Peer-to-Peer conferencing
- PDM integration

Base supports the following optional features:

- ECAD Viewer (PCB and Schematic file viewing, markup, measurement, DFX, and printing)

Standard

Standard provides an integrated environment for viewing data from multiple sources, including CAD, ERP, PDM, and legacy systems. An easy-to-learn user interface encourages collaboration among users without requiring complex training.

Features provided by Standard include:

- All the functionality provided by Base
- Direct read of 3D VRML and STL formats
- Advanced 3D viewing
- Enhanced navigation features
- Ability to view and interact with product structure
- Selecting parts by area or volume

- Ability to control visibility by layers defined in the CAD environment
- Advanced 3D measurements
- 3D markups and 3D GD&T markups
- 3D image capture
- Enhanced .plmxml file support
- Vis Issues Manager

Standard supports the following optional features:

- ECAD Viewer

Standard supports the following optional file converters:

- IGES
- STEP
- DXF

Professional

Professional provides access to several add-on modules that further extend the analysis capability of Lifecycle Visualization while also enabling users to author content.

Features provided by Professional include:

- All the functionality provided by Standard
- Advanced navigation features
- Ability to create and save alternate hierarchies
- 3D transformation, manipulators, and part manipulation mode
- Honor constraints in session files or PLM XML
- Advanced cross section functionality
- Comparing similar 3D models
- User-defined 3D coordinate systems
- Quick Color tool
- True Shading
- Advanced appearance tools
- Outline capture

- Creating and managing callouts and symbols
- Creating and editing thrustlines
- Generating exploded views
- Creating and playing motion (.vfm) files
- Capturing movies
- CAE results viewing
- Viewing Visualization Illustration documents
- Report generation
- Stereo viewing
- Virtual Reality device support
- Ability to export JT, Nastran, Robface, and VRML files
- Ability to export .plmxml files

Professional supports the following optional modules:

- Visualization Illustration
- Concept Desktop
- Concept Showroom
- Variation Analysis
- Quality Producer (Windows only)
- ECAD Viewer
- Visual Reports
- Animation authoring
- .vfz collaboration file authoring
- ADAMS conversion (Windows only)
- STEP file export
- MetaVPDM

Professional supports the following optional file converters:

- IGES

- STEP
- DXF

Mockup

A real-time digital prototyping solution, Mockup combines a wide range of features with a robust set of dynamic analysis tools to help engineers identify defects in digital products at a much earlier stage of the product design cycle.

Features provided by Mockup include:

- All the functionality provided by Professional
- Dynamic interference checking to find and display interference quickly during motion playback
- Matrix clearance analysis to perform complete analysis on large, 3D product databases
- Create and manage part constraints
- 3D grouping
- Filter queries
- Area and mass properties reports
- 3D alignment
- Volume clipping
- Hide obscuring geometry
- Color application
- Part editing
 - o B-Rep face reversing
 - o Re-tessellation
 - o Decimation
 - o Visibility simplification
 - o JtOptimize

Mockup supports the following optional modules:

- Visualization Illustration
- Concept Desktop
- Concept Showroom
- Variation Analysis

- Quality Producer (Windows only)
- Jack
- ECAD Viewer
- Visual Reports
- .vfz collaboration file authoring
- ADAMS conversion (Windows only)
- STEP file export
- MetaVPDM
- Analysis
- Animation authoring
- Path planning
- ClearanceDB

Mockup supports the following optional file converters:

- IGES
- STEP
- DXF

Convert and Print

Convert and Print are flexible command-line conversion and print software utilities that augment the power of the Lifecycle Visualization products. Both applications provide you with tools to convert and print many file formats, resulting in consistency and efficiency.

The key advantage to Convert and Print is their capacity to integrate effectively both native and external file format converters. By integrating the converters, you can convert original files directly into a supported file format. You can also print these files directly into the format required by your printer.

Chapter 3: Deprecating platform announcement

Siemens PLM Software will discontinue support for Teamcenter lifecycle visualization ClearanceDB (client and proxy tiers) on all Sun platforms, starting with Teamcenter 12.x. This includes Clearance Calculator (ClearanceExe), ClearanceDB Client (ClearanceDbClient), and ClearanceDB Proxy (ClearanceDbProxyServer and ClearanceDbProxyClient). ClearanceDB Server tier support on Sun will remain consistent with Teamcenter Server platforms.

Chapter 4: What's new

What's new overview

This Teamcenter lifecycle visualization release includes the following new features and enhancements. Descriptions are categorized by product level and optional module.

New features for Base

Highlight model views for selected PMI

When you are viewing a 3D model with PMI, you can find and display the model views that contain selected PMI.

When you right-click the selected PMI, and choose **Related Model Views**, you can choose from three options:

- **Highlight in Tree**

The model views containing the selected PMI are highlighted on the PMI page of the Project Workspace.

- **Find with Gallery**

The model views containing the selected PMI are listed on the Model Views page of the Project Workspace.

- **Show View**

The model view containing the selected PMI is displayed in the Viewing window. If the PMI is contained in more than one model view, choose **Show View** again to cycle through the model views.

Background geometry is not cross-sectioned

Parts that contain the property **TcVis_Concept_Background_Geom** on leaf components are now considered part of the background or environment and do not have cross sections applied to them.

Sample background parts are included with the example files in your installation:

install_directory\Siemens\Teamcenter\X\Visualization\Examples\Concept\Models\Environments.

Product views reflect structure changes

Product views are more robust to line-balancing structure changes performed in Manufacturing Process Planner. Product views opened with Teamcenter lifecycle visualization update to reflect structure changes for plant bill of process (BOP) lines that are moved with a cut-and-paste action at

the level of consumed lines or higher. This enhancement applies to the original plant BOP as well as any plant BOPs generated using the original plant BOP as a template.

New features for Standard

View properties of 4GD partitions

When you send 4GD data to the stand-alone viewer or the embedded Lifecycle Viewer, you can now view the properties of the partition nodes.

New features for Professional

Immersive mode enhancements

The following enhancements are added for working with immersive devices:

- Conferencing with immersive devices is enhanced:
 - o Conference participants can collaborate and share cross section, measurement, and freehand markup information in real time without changing leadership.
 - o An avatar appears for each conference participant, showing the head position and orientation.
 - o A new button in the immersive conference interface enables a conference participant to become the conference leader.
 - o The conference leader is designated with a special icon.
- Tooltips are added to immersive mode to aid users in selecting various functionality.
- When in **Attach/Release mode**, you can use the dial pad or joystick to move the attached objects closer or farther away.

When you move the attached part closer to its original position, a semi-transparent shape appears to represent the part's original position. A tooltip guides you to place the part back in its original position.

- Snapshot functionality in immersive mode is enhanced with a button in the viewfinder that enables you to more easily add a snapshot. You click the button to add a snapshot. A preview of the snapshot appears to confirm the snapshot was captured.

Also, snapshots are consistent between desktop and immersive modes.

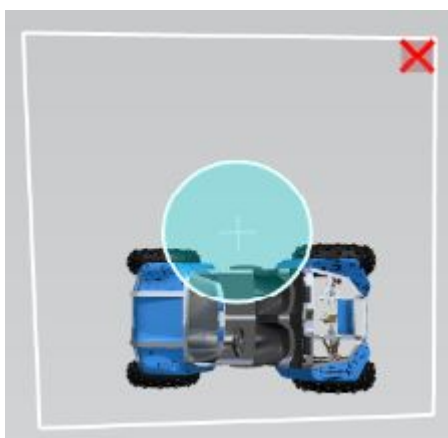

New features for Mockup

Path generation improvements

Path quality is improved, and path generation results are more predictable. In path planning, step size is removed since uniformly segmented path results are no longer generated. Instead the generated path result includes only the key points on the path required to guarantee the static clearance value is satisfied for the entire path.

Since the new path can be a sporadic set of points, the Motion Playback player now includes an option to choose either a time-based or a frame-based playback. The time-based setting allows the new non-linear paths generated by path planning to be played back based on the length of the path instead of the number of points on the path. This enhances motion playback in applications such as dynamic clearance checks.

Clearance analysis enhancements for 4GD objects

Clearance analysis is enhanced with support of additional 4GD objects:

- **Multiple subsets of clearance calculation subsets**

You can load and visualize ClearanceDB results for 4GD worksets referencing multiple subsets, or more precisely, 4GD subset definitions. The subsets of a workset can be subsets of a single 4GD product design or of multiple 4GD product designs. The subsets can be disjointed or they can intersect.

The ClearanceDB results to be loaded can be based on **ObjectType** of **Workset** or on **ObjectType** of **ClearanceCalculationSubset**.

Configure **ObjectType** in the **Clearance.cfgglobal** file and **ModelID**, **ClearanceCalculationName**, and **PartitionSchemes** in the **Clearance.cfgproduct** file.

Before loading ClearanceDB results, the viewer examines the content of the database. If workset based results exist in the database they are loaded; otherwise the viewer attempts to load clearance calculation subset(s) results. In general, a single ClearanceDB result can be loaded

multiple times, at most once per a subset. A new column, **Subset**, is available to add to the clearance results list to enable you to determine which subset a clearance result belongs to.

- **Inferred Partition Attributes**

You can now analyze clearance results for 4GD partitions. This includes the support of inferred attributes for 4GD partitions in addition to the legacy support of product structure attributes. Inferred attributes can be displayed in the **Clearance Results** window. They can also be part of both client and server side clearance results filter definitions.

You must configure these settings:

- o **PartitionAttribute** in the **Clearance.cfgglobal** file, similar to the **Attribute** setting.

- o In **Clearance Results Preferences**:

On the **General** tab, use **Show 4GD partition scheme legend** to display the partition scheme mapping as a legend within the **Clearance Results** window.

On the **Columns** tab, use **Generate optional 4GD partition scheme columns** to choose whether to the generate 4GD partition attribute list for optional columns.

Clearance results preferences enhancements

The default display options for the **Clearance Results Preferences** dialog box are updated to improve usability.

- Element 1 and 2 display:
 - o On the **Element Display** page, when **Element1** or **Element2** is selected, the **Transparency** is set to 75 percent.
 - o Also on the **Element Display** page, **Feature Edges** is selected so that feature edges are on.
- Intersection volume display (the area where Element 1 and Element 2 intersect):
 - o On the **Element Display** page, when **Intersection Volume** is selected, the **Transparency** is set to 100 percent (opaque).
 - o On the **Analysis** page, in the **Intersection Volume** section, **Show** is selected to automatically display the intersection volume for penetrating element pairs by default.
- Contact and penetration point display:
 - o On the **Analysis** page, the **Contact and Penetration Points** values are changed:
 - The default size of the **Most severe penetrations** and **Selected contacts and penetrations** is changed from **3** to **4**.
 - The default color of the **All Contacts** color well is changed to cyan.
 - The default color of the **Less severe penetrations** color well is changed to orange.
 - o Also on the **Analysis** page, the default setting for **Displayed Regions** is changed to **All**, so you see all regions of contact/penetration for each pair.

- Penetration vector display:

On the **Result** page, in the **Penetration Vector** section, **Show** is selected to display an arrow to visually represent the depth of a clearance penetration. The default color has been changed from red to green.

Enhancements to clearance element pair analysis

The interfaces used during the analysis of clearance of element pairs are updated for better usability.

- In previous releases, bounding boxes around contact/penetration points were always aligned to the XYZ coordinate axes. Now contact/penetration points have a *best-fit* bounding box for better visualization of the points within each contact/penetration region.
- On the **Analysis** tab of **Clearance Results Preferences**, **Show** for **Intersection Volume** is now activated by default. When you enter element pair analysis mode, if **Display only** is selected, **Advanced Transparency** is activated automatically. When you leave element analysis mode, the original value for **Advanced Transparency** is restored. Leaving element pair analysis mode is defined as one of these four actions:
 - o You disable clearance analysis.
 - o You close the **Clearance Results** window.
 - o You choose **Clear Analysis**.
 - o You close the open view and/or document.
- You can display a summary box showing the element pair result number and the region of contact or penetration for the result shown in the Viewing window. A new preference, **Onscreen Analysis Summary**, enables you to display the summary and select its font size. This summary makes it easier to see your place in the results list without having the **Clearance Navigation & Analysis** dialog box open.

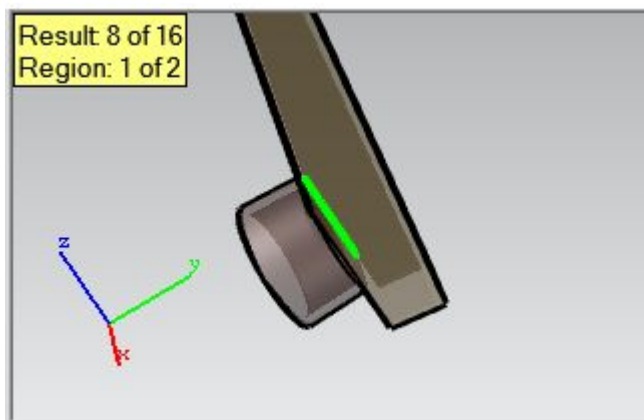

- The **Clearance Navigation & Analysis** dialog box, used when analyzing the clearance of element pairs, is reorganized and is updated with new features.
 - o New **Zoom/Seek** options are added to enable you to adjust the view of the displayed result in the Viewing window.

- o The **Create distance lines** option is now **Show** to be more consistent with other annotation types, and it is moved to the **No Distance Lines Study** section.
- o The **Actions** section consolidates several different commands in a single location.

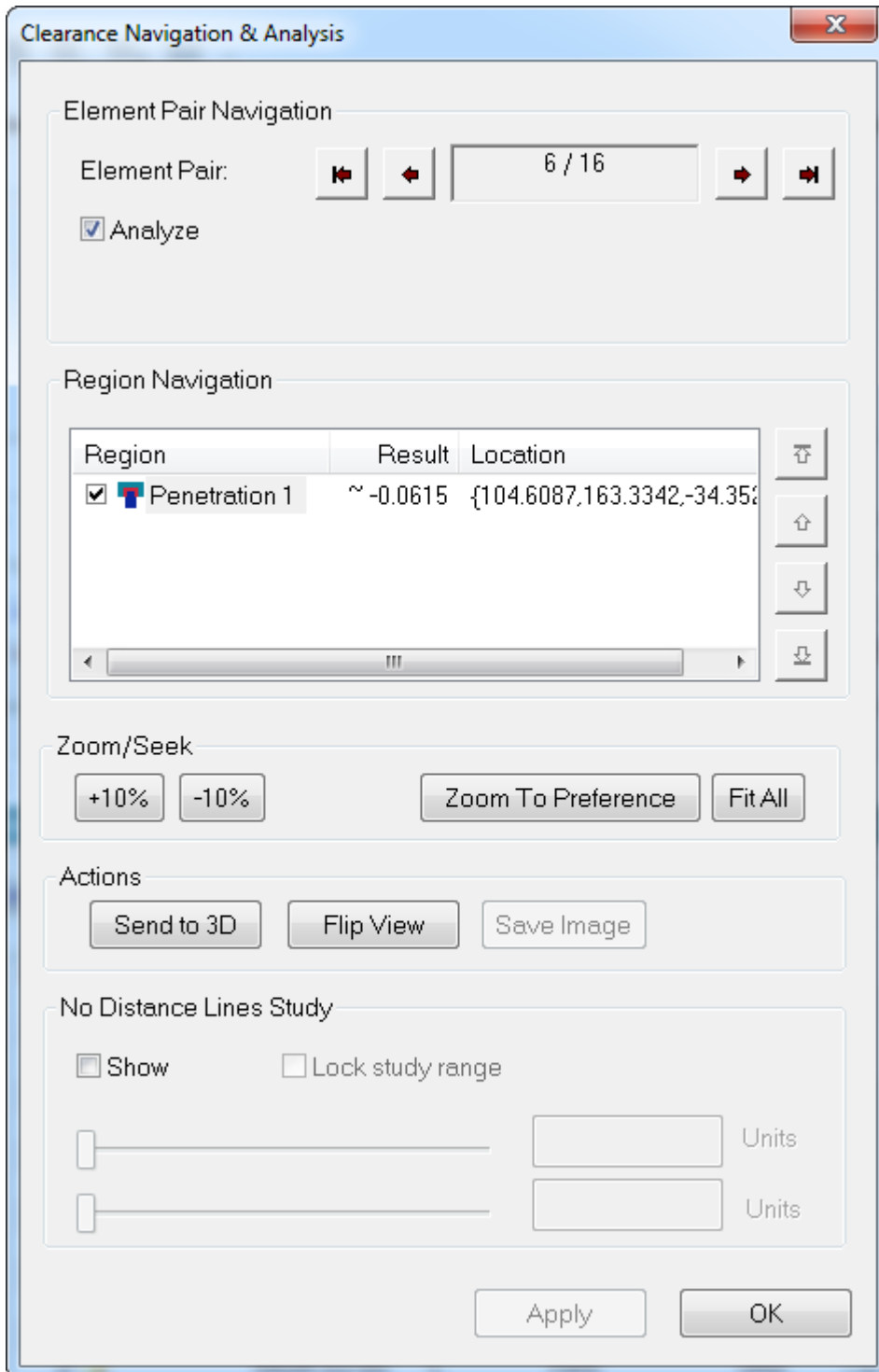

- A new preference provides you with more control over camera settings when navigating results in the **Clearance Navigation & Analysis** dialog box. The **Only apply when requested** option on the **Result** tab of **Clearance Results Preferences** controls the camera settings as follows:

When this option is selected:

The camera settings are not automatically applied during result navigation, but they are when you click **Zoom to Preference** in the **Clearance Navigation & Analysis** dialog box (or press Ctrl and the + key). This allows you to browse the clearance issues at the element pair level and only zoom/seek to the current region when needed.

When this option is not selected:

The camera settings are automatically applied during results navigation as usual.

- The **Open Clearance Navigation Dialog**  button is added to the **Clearance Results** toolbar to open the **Clearance Navigation & Analysis** dialog box.



- The **Column Filters** in the **Clearance results list** are activated by default.
- The **Clearance Toolbox** is displayed by default.

New features for Variation Analysis

Point Measurement Generator enhancements

The **Point Measurement Generator** command has the following new options and enhancement:

- (1) **3D**—Selects all the points in the parts you select by drawing a rectangle around them in the Viewing window.
 - (2) **Reset Spec Limits**—Clears all the existing specification limits applied to the selected points in the point selection list.
 - (3) **Apply Direction Vector** —Lets you specify a direction vector without affecting the specification limits.
- (4) The default **LSL** and **USL** specification limits are no longer set.

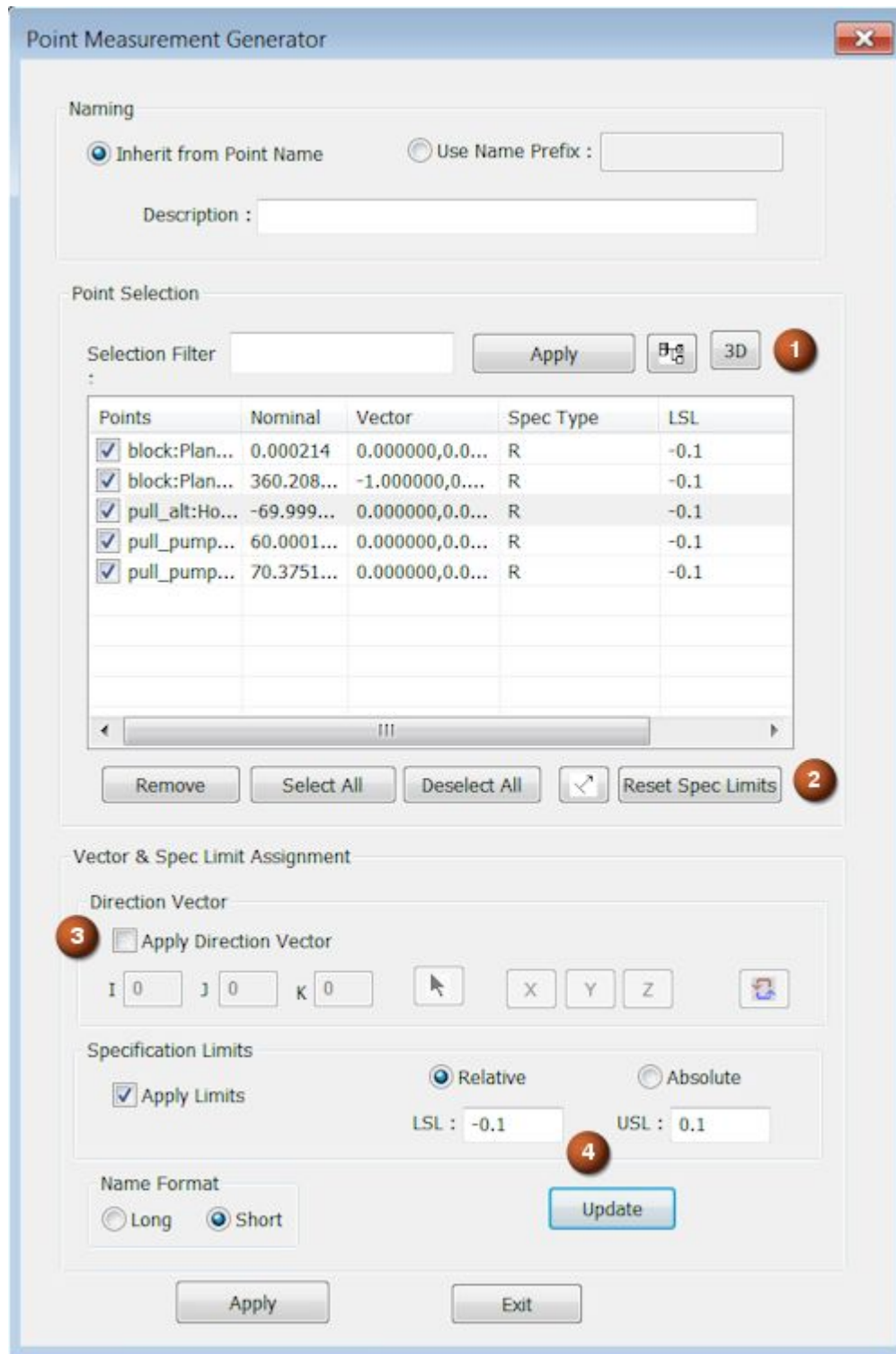

Optionally specifying datum gage diameter

You can now specify a datum reference frame gage diameter when the value cannot be determined during the initialization of validation or simulation.

This occurs occasionally when the datum gage diameter used during feature fabrication cannot be calculated.

For example, in the following image, the **Hole X** feature references datum reference frame **[C|B(M)]**.

Because a **0.2** perpendicularity tolerance is applied to **Datum C**, the gage size of **Datum B** when applied at Maximum Material Condition (MMC) for the fabrication of feature **Hole X** is unknown.

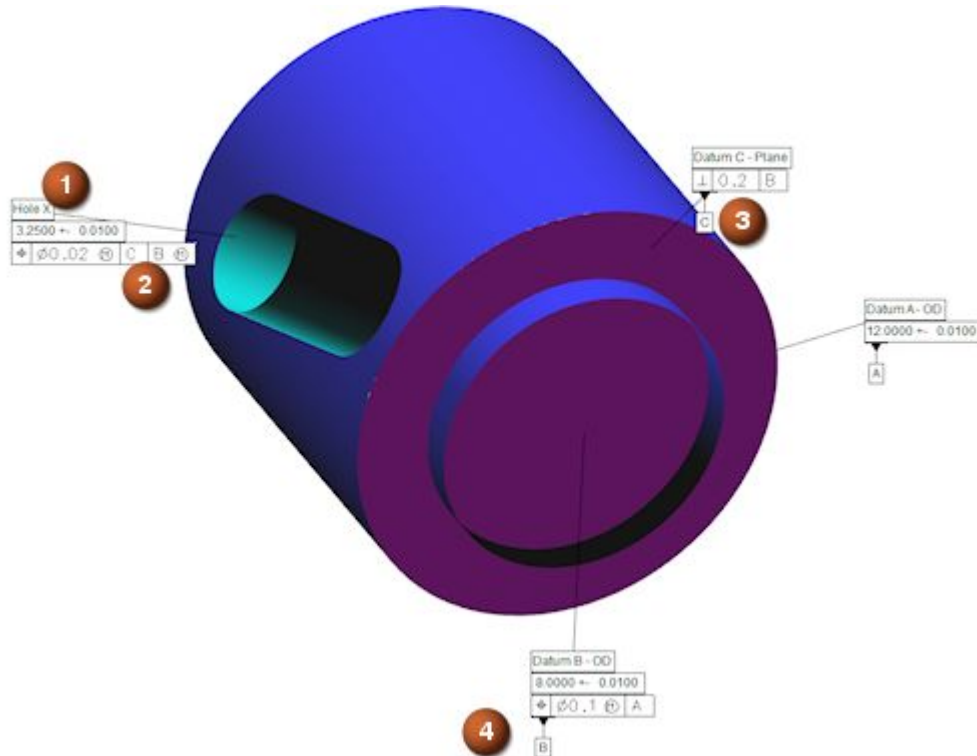

- (1) **Hole X**
- (2) **[C|B(M)]**
- (3) **Datum C**
- (4) **Datum B**

In this case, during the initialization of validation or simulation, the following message is displayed:

```
Part: Part
```

```
Datum reference frame gage diameters cannot be determined for:
```

```
[C|B(M)]
```

```
In order to specify a specific gage diameter, use the notes field in the part properties dialog box.
Custom!
```

```
[C|B(M)] followed by diameter_1 diameter_2
```

To accurately fabricate the **Hole X** feature using an appropriate gage diameter, the user can specify a gage diameter for **Datum B** on the **Notes** tab of the **Part Properties** dialog box.

The syntax for specifying the gage size is **Custom [C|B(M)] 8.0**, where **8.0** is the desired gage diameter for **Datum B**.

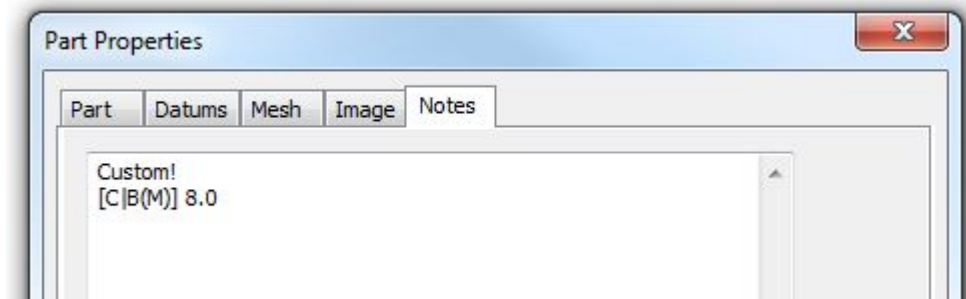

If the gage diameter is not explicitly specified as **8.0**, then the datum reference frame gage diameter of **7.89** (the virtual condition of $8.0 - 0.01 - 0.1$) is used.

For a video on how to calculate and specify the gage diameter for cases when the software cannot determine the value used during feature fabrication, see the **Unresolved DRF Gage Size** article in the [Tecnomatix Knowledge Base](#).

Automated DPV Lite data linking

The **Link Feature Tolerance To DPV Lite Attribute** command is enhanced with **Automated Attribute Mapping** options, so you can automatically link and map Variation Analysis features to DPV Lite attributes.

You can only link each Variation Analysis feature to a single DPV Lite attribute.

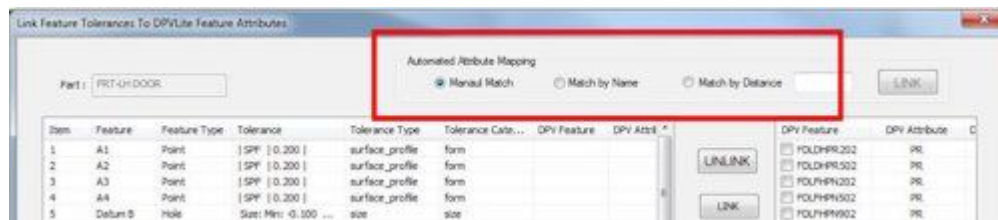

You can select from the following methods of linking; however, once linked, the matched link cannot be overridden or relinked by another method:

- **Manual Match**—Lets you manually select the Variation Analysis feature and DPV Lite attribute to link.
- **Match by Name**—Matches a Variation Analysis point feature to a DPV Lite attribute whose name matches the name you input.

Note

The matching is not case-sensitive and the name you input must match the DPV Lite attribute name.

- **Match by Distance**—Matches a Variation Analysis point feature to the closest DPV Lite attribute within the distance you specify.

Note

In the case of multiple results, the closest attribute by distance is used.

Automated feature naming

Use the new **Naming** Process Document preference to define a naming convention for the default names of features created in a part.

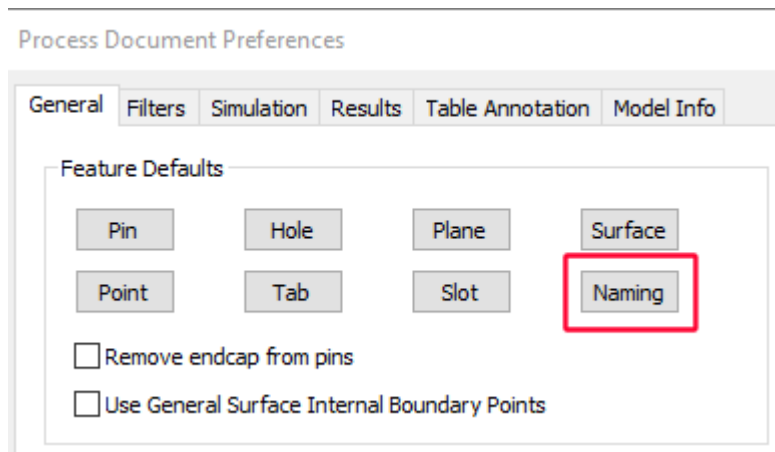

You can enter feature-naming syntax to define the naming conventions for features and sub-feature points.

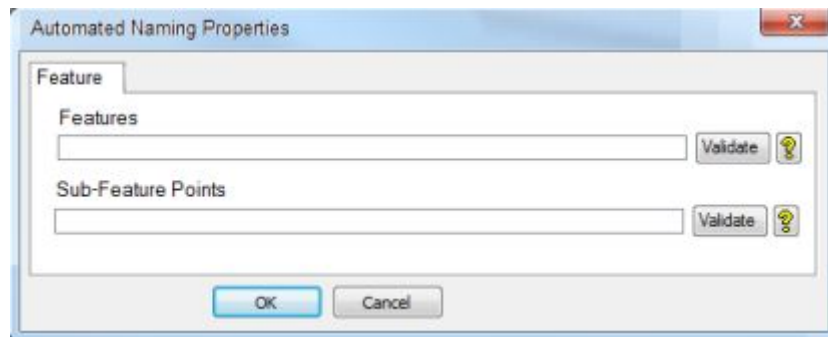

You can apply the following properties in a feature-naming string:

- Feature type
- Custom text
- Parent name, including which consecutive characters to include or omit
- Counter

For example, the feature string `<Type_D>"—"<Parent5-8>"__"<Counter01>` for a parent part named **P34H9845** results in a hole feature named **Hole—9845__01**.

Chapter 5: Supported platforms and locales

Supported platforms

For information about the platforms on which you can run Teamcenter lifecycle visualization, see the Hardware and Software Certifications page on GTAC:
https://www.plm.automation.siemens.com/en_us/support/gtac/certifications.shtml.

Supported locales

The Lifecycle Visualization application and help are localized for the following languages:

- Chinese (Simplified and Traditional)
- Czech
- French
- German
- Italian
- Japanese
- Korean
- Polish
- Portuguese (Brazil)
- Spanish
- Russian

Some optional modules are available in English versions only, including:

- ClearanceDB
- Convert and Print
- Jack
- Quality Producer
- Variation Analysis

Note

- A separate installer is required for each language version of the help.
- Because of operating system limitations, Teamcenter lifecycle visualization does not support non-ASCII characters, including 8-bit accented Western European and multi-byte characters, in file names.

Chapter 6: System requirements

General system requirements

Performance is directly related to system processor speed, RAM, and your video card. Although Lifecycle Visualization will run if your system meets the minimum requirements described in this section, your machine should be considerably more powerful for you to get the full benefit of the visualization features.

Minimum required system

For 3D models, 2D images, and ECAD images, your system should have a 1 GHz or better processor, 1 GB RAM, 2 GB of virtual memory, and a supported graphics card with 128 MB of dedicated video RAM and support for OpenGL 2.1 or greater.

Minimum recommended system

For 3D models, 2D images, and ECAD images, your system should have a 2 GHz or better 64-bit processor, 4 GB RAM, 6 GB virtual memory, and a supported graphics card with 256 MB of dedicated video RAM and support for OpenGL 3.2 or greater. For more information on which graphics adapters are supported, see *Graphics hardware requirements*.

Note

<http://www.plm.automation.siemens.com/locale/support/gtac/certifications.shtml>

These are only recommendations. For information on officially supported workstations, video cards, and drivers, see the Hardware and Software Certifications page on GTAC: https://www.plm.automation.siemens.com/en_us/support/gtac/certifications.shtml.

License server requirements

Lifecycle Visualization products use the Siemens PLM Software Common Licensing Server for served licenses.

For information about Siemens PLM Software that supports Teamcenter 11.6 lifecycle visualization, see the Hardware and Software Certifications page on GTAC: https://www.plm.automation.siemens.com/en_us/support/gtac/certifications.shtml.

Teamcenter community collaboration visual conferencing requirements

To use Teamcenter 11.6 lifecycle visualization with Teamcenter community collaboration visual conferencing you must have Teamcenter community collaboration conference server 11.1 or higher

Teamcenter community collaboration visual conferencing is not supported on older conferencing servers.

Graphics hardware requirements

Supported graphics adapters for use with Teamcenter lifecycle visualization include the following professional 3D graphics adapters with their professional drivers:

Manufacturer	Models
NVIDIA	Quadro, QuadroFX, Grid
AMD	FireGL, FirePro
Intel	HD 4600 and newer

For full confidence that all of the advanced features of Teamcenter lifecycle visualization are displayed, including effects such as high-quality transparency, shadows, mirrors, CAE analysis results, intersection volumes, and other features requiring advanced graphics capabilities, use a certified system. Siemens PLM Software and our OEM partners rigorously test specific graphics adapters and drivers on a select set of workstations. Graphic adapters and drivers that pass are certified for use with a particular version of Teamcenter lifecycle visualization.

For information about certified systems, see the Hardware and Software Certifications page on GTAC (<http://www.plm.automation.siemens.com/locale/support/gtac/certifications.shtml>) and follow the link to *Hardware (Graphics Card) Certifications*.

Note

Starting with Lifecycle Visualization version 10.1, if your graphics card supports OpenGL 3.2 or later, Lifecycle Visualization uses advanced OpenGL features to improve 3D rendering performance, including making use of memory on the graphics card. If you work with large models, we recommend graphics cards with 2GB or 4GB of GPU memory, or more. While exact memory requirements are highly situation specific, a rough guideline for required graphics card memory is 1 GB of graphics memory for every 2 GB of loaded geometry data.

Consumer line and 2D graphics adapters

We do not recommend consumer lines of graphics adapters. These adapters and drivers are designed for playing games and emphasize frame rate over correctness. Drivers for consumer graphics are serviced by driver development and ISV partner teams separate from those for professional 3D adapters.

However, even these video adapters, if you have the most current graphics driver, usually work at a reduced effects level with Lifecycle Visualization. It may be necessary to reduce the performance settings.

Note

When the OpenGL level of a graphics adapter is not capable of rendering an advanced visualization effect, the visual effect is silently omitted.

Some graphics adapters, especially those manufactured before 2008, contain issues that prevent Lifecycle Visualization from displaying certain specific features properly, regardless of their OpenGL support level claims.

Resolving graphics adapter issues

You are encouraged to report graphics display problems found on recommended and certified hardware to <http://www.siemens.com/gtac>. We attempt to reproduce the problem. If a reproducible problem is determined to lie within Lifecycle Visualization software, we fix it directly; if a problem is found with the graphics driver, we work with the graphics vendor to isolate the issue and assist them as necessary to produce a driver patch.

We do not attempt to resolve problems that cannot be reproduced on recommended or certified hardware; we advise you to take such issues directly to the graphics adapter manufacturer.

Help requirements

To run the Teamcenter lifecycle visualization help, the following requirements must be met:

- Windows:
 - o Internet Explorer – 8 or higher
 - o Firefox – 16 or higher
 - o Chrome – latest release
- Linux:
 - o Firefox latest release
- Mac OS X:
 - o Safari – latest version
 - o Chrome – latest version
- The Siemens PLM Documentation Server requires a supported 64-bit Java Runtime Environment (JRE) on the PLM Documentation Server host. The PLM Documentation Server does not support 32-bit Java.

Make sure a supported 64-bit JRE is installed on your PLM Documentation Server host.

- To watch videos and simulations, the Adobe Flash Player version 10 or later is required. You can download the latest version of the player from this location:

<http://get.adobe.com/flashplayer/>

- Some portions of the help are in the PDF format, which requires Adobe Acrobat Reader (any version). You can download the reader from this location:

<http://get.adobe.com/reader/>

Note

The help files are no longer packaged with the Teamcenter lifecycle visualization installer. To install the help locally, you must install the Siemens PLM Documentation Server and the Teamcenter lifecycle visualization help, which are installations separate from the installation of Teamcenter lifecycle visualization. You must also set the port and server for help access for clients during the product installation or after the product installation. A separate installer is available for each language version of the help. Alternatively, you may access the help from the [Siemens PLM Software Doc Center site](#), which you are directed to when you select the **Help** commands in the software after you choose not to install help during the software installation.

Firefox caveats

Firefox recommends that users update to the latest version for security issues surrounding Java. They do not recommend using older versions of Firefox due to these issues. See the following for more information:

<http://support.mozilla.org/en-US/kb/latest-firefox-issues>

Chrome caveats

By default, Chrome does not launch local files (e.g. file:///). To enable this, users have to start Chrome from the command line with the `--allow-file-access-from-files` switch. One source for how to do this is: <http://www.askyb.com/chrome/open-local-file-in-google-chrome/>

PDF requirements

To view, mark up, and print PDF and Postscript files on Mac and Linux systems, you must install and use Ghostscript.

1. You can navigate to the following Web site to download and install the Ghostscript software:

<https://download.industrysoftware.automation.siemens.com/open-source/ghostscript>

2. After installing Ghostscript on Mac or Linux systems, add the following to your `vvcp.darwin.cfg` or `vvcp.linux.cfg` file in the `<installation_directory>/app_defaults/` directory:

***PSPath:** `<path to the 'gs' executable>`

For example, add ***PSPath:** `/usr/apps/gs864/bin/gs`.

Ghostscript is also required to work with Postscript files on Windows systems. You can download the Windows version from the site shown above.

Tip

To configure Ghostscript to use system fonts on Windows, install Ghostscript before you install Lifecycle Visualization.

IDW requirements

To work with Autodesk Inventor .idw 2D files, you must have one of the following:

- Autodesk Inventor
- Autodesk Inventor View, a freely distributed application available from Autodesk
- Design Tracking, a freely distributed utility available from Autodesk

Note

- Support for Autodesk Inventor .idw files depends on the version of the Autodesk Inventor, Autodesk Inventor View, or Design Tracking that you have installed. For example, if you have Design Tracking 7, then Inventor 5.3 through 7 files are supported. If you have Autodesk Inventor View 11, then Inventor 5.3 through 11 files are supported.
- Autodesk Inventor .idw files prior to version 5.3 are not supported.

ADAMS conversion requirements

The ADAMS conversion feature, which converts RES files to the VFM motion file format, requires the Professional or Mockup product configuration, as well as an additional license. It is supported on Windows only.

Visualization Illustration requirements

To install Visualization Illustration, when you install Teamcenter lifecycle visualization by right-clicking the **setup.exe**, you must select **Run as an Administrator**. This is necessary to register **VisVisioHostApp** in Windows.

Visualization Illustration is supported on Windows only (Windows 7 or Windows 10), and requires one of the following:

- Visio 2010 with Service Pack 2, either the 32-bit or 64-bit version
- Visio 2013 or 2016 with the latest patch, either the 32-bit or 64-bit version

Authoring Visio-based work instructions in Teamcenter Manufacturing is supported only with 64-bit Visio 2010.

Standard, Professional and Premium editions of Visio are supported.

Convert and Print requirements

- The Convert and Print Office Automation feature requires Microsoft .NET Framework. Version 4.5.x is recommended.

You can download Microsoft .NET Framework for your version of Windows from <http://www.microsoft.com/en-us/download/>

- To view, convert, and print Microsoft Office files, you must have Microsoft Office installed.

ClearanceDB requirements

For information about the requirements for ClearanceDB, see *ClearanceDB Administration* in the Teamcenter lifecycle visualization help.

Interoperability with other software

For information about Siemens PLM Software that supports Teamcenter 11.6 lifecycle visualization, see the Hardware and Software Certifications page on GTAC: https://www.plm.automation.siemens.com/en_us/support/gtac/certifications.shtml.

Teamcenter client communication system (TCCS) requirements

The Teamcenter client communication system (TCCS) manages communication and file transfers between Teamcenter clients and servers. TCCS contains the Teamcenter Server Proxy (TSP) application which manages HTTP/S communication with a Teamcenter server and provides support for forward proxy, reverse proxy, and Kerberos authentication. TCCS also contains the FMS client cache (FCC), which uploads files from your workstation to a Teamcenter volume and also downloads requested files from the volume to your workstation. The Teamcenter lifecycle visualization integration with Teamcenter requires an FCC to transfer volume data between Teamcenter and the viewer.

TCCS is normally installed with the Teamcenter rich client. If the Teamcenter rich client is installed on your machine, most likely no additional installation steps are necessary. If you do not have the Teamcenter rich client installed, but you need to transfer volume data between Teamcenter and the viewer, you can download the TCCS installer from the GTAC site <http://www.siemens.com/plm/support>. For more information, see the *Lifecycle Visualization Installation* guide.

Note

An FCC is required for Teamcenter 8 onwards. Although an FCC is not required for Teamcenter 2007, it is recommended.

For information on installing TCCS with the Teamcenter rich client, refer to *Windows Clients Installation*, *Linux Clients Installation*, or *Macintosh Clients Installation* within the Teamcenter documentation.

Chapter 7: Resolved Problem Reports

Customer problem reports (PRs) resolved for Teamcenter 11.6 lifecycle visualization include:

PR	Product	Category	Summary
3056942	VISVIEW	3D_MEASUREMENT	3D associative measurements not working on certain data.
9166015	VISVIEW	3D_MEASUREMENT	Single 3D measurement ignores diameter setting in 3D Measurement Preferences.
9179459	VISVIEW	3D_MEASUREMENT	VisDispMeasurementEntity MeasureDistance shows null result.
9181303	VISVIEW	3D_MEASUREMENT	Measurement automation API returns NULL instead of measurement entity.
9200609	VISVIEW	3D_MEASUREMENT	Aligning a section with measurement is not working with leaf structure.
9212238	VISVIEW	3D_MEASUREMENT	Changing measurement preferences from Radius to Diameter does not work.
9224996	VISVIEW	3D_MEASUREMENT	In 3D measurement, the Diameter preference switches to Radius after a measurement.
9093296	VISVIEW	3D_PSLOADER	Fetching FMS tickets while double-clicking on parts.
9052551	VISVIEW	3D_VIEW_CONTROL	Zooming issues (data specific).
7822801	VISVIEW	APPEARANCES	Measurement not showing graphics view when user selects Show light option.
9239117	VISVIEW	APPEARANCES	Korean language format setting causes TcVis to stop responding.
9271257	VISVIEW	APPEARANCES	Viewer stops responding when loading appearance information of JT.
8390370	VISVIEW	CLEARANCE	Missing documentation for custom reports for clearance results.
9025001	VISVIEW	CLEARANCE	Misleading German translation for new Clearance Distance Lines Filter.
9161076	VISVIEW	CLEARANCE	Clearance Report has incorrect information with additional fields.
9182574	VISVIEW	CLEARANCE	Matrix Clearance takes longer after data is loaded and unloaded.
9195180	VISVIEW	CLEARANCE	Matrix group-to-group clearance no longer possible after UI change in 11.x.
9112166	VISVIEW	CROSS_SECTION3D	3D Section: Align Plane > To Curve At Point doesn't work as expected.
9215897	VISVIEW	CROSS_SECTION3D	Viewer stops responding after aligning a section plane.
9222105	VISVIEW	DIRECTMODEL	WF and curvesets are not visible behind transparent parts.
9184621	VISVIEW	FRAMEWORK_PC	Viewer dialog boxes accept non-numeric characters in numeric input fields.
9196865	VISVIEW	INSPECTOR	PMI Fidelity in JT Inspector: wrong nominal angle units for PMI Angular Dim.

PR	Product	Category	Summary
9196890	VISVIEW	INSPECTOR	PMI Validity in JT Inspector: <unknown(78)> error for Lightweight section view.
9198156	VISVIEW	MODELVIEW_GALRY	Tree view of Model View tab displays MVStyle elements.
9208863	VISVIEW	MODELVIEW_GALRY	Properties of selected PMI is disabled if selecting from Model View tab.
9200711	VISVIEW	PARASOLID_INTEG	In 3D Measurement, a point on edge measurement with section lines is wrong.
9078612	VISVIEW	PATH_EXTRACTION	Adding a key position for path planning will not populate in the key positions.
9153994	VISVIEW	PATH_EXTRACTION	Path planning generation fails with collision when wireframe is turned on.
7823147	VISVIEW	PMI	PMI Ballon Note: NX component is highlighted; in TcVis, only 1 face is highlighted.
7896365	VISVIEW	PMI	By selecting a PMI label the wrong face gets highlighted.
9088038	VISVIEW	PMI	Model View of translated JT shows PMIs that are not content of the Model View.
9099489	VISVIEW	PMI	PMI outline gets zoomed when being moved/dragged.
9187474	VISVIEW	PMI	PMI highlighting Solid Body problem.
9057061	VISVIEW	PUBLISH	Shaded Asset Capture function isn't displaying the same image as the 3D part.
9133337	VISVIEW	SESSION	JT2Go 11.4 Issue Reading VFZ File.
9233448	VISVIEW	SESSION	Not able to perform Save Session As for plmxml files.
9239083	VISVIEW	SESSION	Save session causes TcVis to stop responding.
9041762	VISVIEW	VISUAL_REPORT	Results are incorrect when setting Japanese as a condition of visual report.
9194830	VISVIEW	VR_DEVICES	VRPN joystick issue.
9252899	VISVIEW	VR_DEVICES	HTC-Vive camera not restored from snapshot as expected.
9219250	VISVIEW	COMMAND_LINE_OP	prepare.exe -PDF results in PDF files with missing characters i and l.
9277717	VISVIEW	EXTERNAL_APPS	PDFControl system stamp configuration not stamping correctly.
9248962	VISVIEW	SECURITY_RISK	7-Zip library upgrade recommendation.
3056676	VISVIEW	VISVSA	Process tree selection not working with 3DSection.
3057421	VISVIEW	VISVSA	Flex Assembly Springback incorrect result unless Loadsteps defined in order.
3057422	VISVIEW	VISVSA	Flex Assembly Springback - More points than there are force/moment IDs.
7620664	VISVIEW	VISVSA	Highlighted part in Project Workspace stops working in VA.
7974070	VISVIEW	VISVSA	VSA: Missing highlight in model tree.
8388971	VISVIEW	VISVSA	Variation Analysis - Not all contributors are included in the analysis.
8549284	VISVIEW	VISVSA	Plane features are not created as intended.
8821927	VISVIEW	VISVSA	Part node not highlighting in tree.

PR	Product	Category	Summary
9016528	VISVSA	VISVSA	VSA batch mode: output of measurement type calculation in results documentation.
9016625	VISVSA	VISVSA	Using VSA in batch mode, the process report sigma range is not considered.
9022414	VISVSA	VISVSA	Derive from feature geometry button not working on ribbon bar.
9045772	VISVSA	VISVSA	VSA parts or features not highlighting in Project Workspace window.
9129784	VISVSA	VISVSA	Data terminated if you do not select a type in Flex Assembly Operation.
9144211	VISVSA	VISVSA	Feature creation issue.
9200119	VISVSA	VISVSA	Zone shift values are invalid for pdo text import.
9233519	VISVSA	VISVSA	Feature list empty when attempting to link part to DPV Lite data.
9263921	VISVSA	VISVSA	The sum of GRAVITY analysis and SPOT analysis does not result in analysis result of GRAVITY+SPOT.
9264479	VISVSA	VISVSA	pdo file stops responding when trying to run a simulation.
9269927	VISVSA	VISVSA	Kinematic Assembly Operation not working.
9277968	VISVSA	VISVSA	TcVis-VA Measurement MathEq crashes.

Chapter 8: Issues and workarounds

Hardware acceleration when running in Ribbon mode

Problem	On systems that contain both discrete and integrated graphics cards, Teamcenter lifecycle visualization may only utilize the integrated graphics card when the Ribbon bar interface is enabled.
Workaround	For discrete graphics, to enable high performance, you must set the VisView_NG.exe program to run in high performance mode. On Nvidia graphics cards, you can do this by assigning the high performance NVIDIA processor to the VisView_NG.exe program. You can set this in Manage 3D Settings in the NVIDIA Control Panel.

Installation options obscured in older Mac OSX versions

Problem	When using some older versions of Mac OSX, during installation, the license server port and help server port options are obscured. This is not an issue if your license server and help server were configured using default settings, because the installer will use the default port 2800, which will match the server configuration.
Workaround	Either update your system to OSX 10.13, or follow these steps: License port: <ol style="list-style-type: none">1. Navigate to /Visualization/license in the installation directory.2. Open the license.dat file with a text editor.3. Follow the instructions in the license.dat file to replace the 2800 port value with the desired port. Help port: <ol style="list-style-type: none">1. Navigate to /Visualization/bin in the installation directory.2. Type this command: <code>update_help_path <docServerName> <docServerPort></code>

Text not selectable in PDFs from Visualization Illustration

Problem	Text is not selectable in PDFs produced from Visualization Illustration using Visio 2013 or earlier. Visualization Illustration produces PDFs with raster quality images and thus text is not selectable.
Workaround	Install the update for Office 2013, KB4018331, dated October 2, 2018, from https://support.microsoft.com .

Cross section issue in virtual reality conferences with previous release participants

Problem	A virtual reality conference participant using the desktop interface in a release prior to 11.6/12.1 may not correctly send cross sections to participants using 11.6/12.1 or later. This issue occurs when the newer release participant has different selections than the older release desktop participant when the desktop participant creates a section.
Workaround	None

UNIX session ends when loading JT data

Problem	When working in UNIX and loading JT data in an embedded viewer in Teamcenter, the session ends.
Workaround	Use the latest version of the NVIDIA driver.

CAE legend annotation does not appear properly

Problem	When exporting CAE data into the JT format using NX12, if you choose the old style JT CAE format (prior to TcVis 11.0), the legend annotation does not appear properly when opening the JT file in TcVis 11.0 or later.
Workaround	Choose the new style JT CAE format (TcVis 11.0 and later) when exporting CAE data into JT in NX12.

Parts not positioned correctly for model views in session packages

Problem	When you load session packages that have model views applied, upon reload of the session package, parts may not be positioned correctly for model views that enforce part transforms.
Workaround	Use Reset Part Position and reapply the model view.

Thumbnails of model views not captured

Problem	When you load a session file that contains model view palettes, and a session file containing a model view palette in Teamcenter is saved using the static configuration, the thumbnails of the model views on the palettes are not captured. You may see ModelView palette entries that are empty.
Workaround	Save the session as dynamic references.

NX PRT loading support

Problem	Teamcenter Visualization supports NX12 PRT loading on Windows only.
Workaround	For other platforms, Teamcenter Visualization supports up to NX11.

Cannot rotate grouped shapes from a stencil list

Problem	Due to a Visio 2013 and 2016 issue, you cannot rotate grouped shapes that are added from a stencil list.
Workaround	None

Cell borders missing in graphical reports

Problem	Due to a Visio issue, cell border lines are missing in tables in DPV graphical reports when printed in PDF format.
Workaround	None

Some charts and tables missing in graphical reports

Problem	Some charts and tables are missing in printed DPV graphical reports when printed in PDF format. This happens when the assets are overlaid over another in the Visio document.
Workaround	In Print Setup on the Advanced tab, select Print as image .

Saving graphical reports as text doesn't save chart and table text

Problem	Due to a Visio and/or Acrobat issue, chart and table text is missing in DPV graphical reports when the PDF is saved as text.
Workaround	In the open PDF file, select all text and copy it in a text editor. - or - Use the feature in PDF-XChange Editor to convert the PDF to text.

Visualization Illustration stops responding when working with gradients on shapes

Problem	Teamcenter Visualization stops responding when you work with the Shapes context menu and modify the gradient.
Workaround	Update Visio 2013/2016 to the latest patch from https://support.microsoft.com .

Values in Variation Analysis not retained or are corrupted

Problem	Values keyed-in in Variation Analysis edit boxes are not retained or are corrupted.
Workaround	Install the Microsoft windows patch KB4041681.

JT Utilities Integration with Teamcenter is obsolete

- Problem** The integration of JT Utilities with Teamcenter is removed from Teamcenter 11.4 and later versions. You may still use JT Utilities as a standalone tool or as an integration tool with any product where this utility is properly configured and integrated. Standalone JT Utilities is available for download from the GTAC download site, under Teamcenter Visualization→JT Translators→PLM Vis: <https://download.industrysoftware.automation.siemens.com/>
- Workaround** Siemens PLM Software recommends opening JT assemblies with the Lifecycle Viewer or the embedded viewers in Teamcenter.

Generating a DPV template from a technical portfolio is slow

- Problem** Generating a DPV template from a technical portfolio is slow.
- Workaround** If Visio is used in VisAutomationServer for updating the DPV templates, set the environment variable **TCVIS_VISAUTOMATIONSERVER_VISIO** to **true** on the client machine where DPV templates are created.

Text not selectable in Visualization Illustration raster quality images

- Problem** In Visio 2013 or earlier, Visualization Illustration produces raster quality images and thus text is not selectable.
- Workaround** Update Visio 2013 to the latest patch from <https://support.microsoft.com>.

Shapes from File menu is not supported with Office 365

- Problem** Visualization Illustration with the Office 365 version of Visio does not support the **Shapes** option from the **File** menu.
- Workaround** Use the ribbon interface to choose **Home** tab→**Stencil** group→**Shapes**.
If shapes do not appear, open shape stencils from Visio 2016 once, close Visio, and then start Teamcenter Visualization.

Error when opening HTML file published from a technical portfolio

- Problem** Due to added Java security restrictions, opening an HTML file published from a technical portfolio may cause an error message.
- Workaround** Add the local folder where the HTML file is stored to the **Exception Site List** in the Java Control Panel, as `file:\\D:/mydir/`

Styles menu in Visualization Illustration causes program to stop responding

- Problem** The program stops responding when you work with the **Styles** context menu, which is available when you select a 3D geometry asset or a shape in an illustration.

Workaround For formatting, from the Application toolbar, choose **Menu** → **Format** → **Text, Line, or Fill**.

Help not compatible with older Documentation Server versions

Problem The Teamcenter 11.6 lifecycle visualization help is not compatible with versions 1.0 and 2.0 of the **Siemens PLM Documentation Server**.

Workaround Install the latest version of the **Siemens PLM Documentation Server**, available on GTAC.

Not responding message appears during clearance analysis

Problem When you perform a clearance analysis in which the part pair analysis takes several minutes, when you click in the main window, the message `Application not responding` appears.

Workaround Click **Wait for the program to respond**, and the calculation will finish.

JT-STEP Bi-Directional Translator support issue

Problem The integration to JT-STEP Bi-Directional Translator does not support the configuration control **writeWhichFiles** for a combination of values **AP242XML,JTPARTS** in interactive and command line mode.

Workaround None

Measurement operation navigation buttons not functional in Variation Analysis

Problem The measurement operation navigation buttons are not functional if there is a general surface feature that does not contain a sub-feature point associated with a minimum feature clearance measurement operation.

Workaround Add at least one sub-feature point to the general surface feature.

Thrustline attached with a leaf component not repositioned correctly

Problem Thrustline attached with a leaf component may not be repositioned correctly upon load if the position of the leaf components parent is changed due to new revision.

Workaround None

Save not deactivated when technical illustration with file is saved

Problem If a file is inserted into a technical illustration, and the technical illustration is saved, the **Save** button is not deactivated.

Workaround Close the technical illustration and click **Yes** when the message appears, `Do you want to Save changes to the file?`

Mismatch between outline geometry and shaded image

Problem	When a 3D geometry asset is created without enabling page extents using the Shaded with Outline option, and then asset is shown both in Illustration with the Show Shaded with Outline option, a mismatch may occur between the outline geometry and the shaded image.
Workaround	Create 3D geometry assets with page extents enabled. If this issue occurs with existing 3D geometry assets created without page extents, update the asset.

Loading a file from Teamcenter may fail if SSO is enabled

Problem	When loading a file from a Teamcenter server to Teamcenter lifecycle visualization running in a cluster system, if the server is configured with single sign-on (SSO), the viewer running on the secondary system may fail to load the data.
Workaround	Teamcenter lifecycle visualization running on the secondary system may have different environment variable settings as the one running on the primary system. Do the following:

1. Create a text file, for example:

C:\tcvis_cluster_user_env_vars.txt

2. Set the system environment variable to point to the file, for example:

```
TCVIS_CLUSTER_USER_ENV_VARS=C:\tcvis_cluster_user_env_vars.txt
```

3. Identify the following environment variables used by Teamcenter lifecycle visualization running on the primary machine:

```
APPDATA
```

```
USERPROFILE
```

```
USERNAME
```

4. Add the information to text file. For example:

```
APPDATA=C:\Users\PV\AppData\Roaming
```

```
USERPROFILE=C:\Users\YourUserName
```

```
USERNAME=YourUserName
```

5. Restart the secondary system.

IPv6 for sockets

Problem	The rich client embedded viewer does not support IPv6 for sockets. In this instance, the viewer will attempt to force an IPv4 connection.
Workaround	If using IPv6, ensure that IPv4 sockets are still enabled.

VBScript in Internet Explorer

Problem	Internet Explorer support for VBScript has changed. The changes may impact existing customer processes and deployments.
Workaround	For details, refer to the information, <i>VBScript in Internet Explorer</i> , located in this file in the installation Examples folder: Automation\Documentation\ref_files\vbscript.htm

AutoCorrect options do not appear in Visualization Illustration

Problem	When you use 64-bit Visio, the AutoCorrect options are not available. These options are available from the Application toolbar when using 32-bit Visio: <ul style="list-style-type: none"> • Menu→Tools→Options→Proofing→ AutoCorrect Options • Menu→Tools→Auto Correct Options
Workaround	Open Visio, and set the options using Tools→Options→Proofing→AutoCorrect Options .

Dotted line appears in SVG file in technical illustration

Problem	When you open an SVG file in Visualization Illustration, a dotted line may appear.
Workaround	The line represents a page break and can be ignored. It does not appear in printed or PDF output.

Linux embedded viewer dialog boxes appear behind the rich client window

Problem	On Linux, embedded viewer dialog boxes may appear behind the main rich client application window.
Workaround	Use Gnome Window Manager. Most other Linux window managers do not work correctly.

UI text does not display correctly for non-English locales on Linux

Problem	Teamcenter lifecycle visualization interface text does not display correctly for non-English locales on Linux.
---------	--

- Workaround** You must specify the language at the login screen to ensure the X Server loads the correct fonts.
- If the *Font Creating Failed* error appears, refer to the workaround below for the *Missing UI text on Linux* issue.

Error when converting a DWG file with an embedded OLE object to PDF

- Problem** An error message appears when you attempt to convert a DWG file with an embedded OLE object to PDF.
- Workaround** Disable macros and change resource settings:
1. In Excel, choose **File**→**Options**.
 2. In the Excel Options dialog box, choose **Trust Center**.
 3. In the **Microsoft Excel Trust Center** section, click **Trust Center Settings**.
 4. Choose **Macro Settings**.
 5. Select **Disable all macros without notification**.
 6. You may need to set the following resource settings in the vvcpl.ini file. These settings require less memory when converting the file.
 - DwgOLERasterQuality=0
 - DxfOLERasterQuality=0

Some CGM files generated by Catia V5 fail to display the image

- Problem** Some CGM files generated by Catia V5 with embedded raster data fail to display the image when loaded into Teamcenter lifecycle visualization. This is because some CGM data generated by Catia V5 can be invalid based on the CGM specification. The invalid data may not impact the rendering of the image, but any found error can cancel the processing of the image.
- Workaround** If the CGM specification check is overridden, the image may still display properly. To enable the override, while Teamcenter lifecycle visualization is not running, create an environment variable named `TCVIS_IGNORE_CGM_RASTER_ERROR`, and set it to any value. If any problems loading CGM files are still present, disable the override by deleting the `TCVIS_IGNORE_CGM_RASTER_ERROR` environment variable and restarting Teamcenter lifecycle visualization.

No connection to hardware devices when immersive mode is activated

- Problem** When the immersive mode is activated, Teamcenter lifecycle visualization does not connect to hardware devices.

Workaround In the **ImmersiveConfig.xml** file, set `<Auto_Activate name=""/>` to a value of the corresponding hardware device server name.

For example, to connect to a VRPN server, set the value as:

```
<Auto_Activate name="VRPN"/>
```

Available options for the hardware device server names are:

TrackD

InterSense

VRPN

If you are using ZSpace, Oculus Rift, or HTC Vive, use the corresponding configuration file.

Animations created with Capture Walk not saved correctly

Problem Animations created with the Capture Walk option under Tracking Camera action are not saved correctly in Tc Vis 11.1.1. Such animation data will not load correctly in later TcVis versions.

Workaround Any Animation data created with the tracking camera action in TcVis 11.1.1 must be recreated in later versions.

Fast Mode and Manual Update options in 3D Section are disabled

Problem The **Fast Mode** option in the cross section preferences and the **Manual Update** menu item and toolbar option are disabled.

Workaround None.

CAE data does not display properly on Linux and OS X

Problem The CAE data does not display properly on Linux and OS X.

Workaround None. The CAE visualization functionality introduced in Teamcenter Visualization 11.1 is not fully supported by the graphics card drivers currently available for Linux and OS X.

Missing CAE units in CAE Viewing

Problem All the CAE units except Millimeters are displayed as Unknown in CAE Viewing.

Workaround None. The CAE units in CAE Viewing are not supported in Teamcenter Visualization 11.1.

Multiple clipped cross sections with capping do not display correctly

Problem	If you create multiple clipped cross sections with capping enabled, the resulting view may render incorrectly. It may look as if you can see through the capped sections and see the backs of the other capped sections.
Workaround	None

Missing UI text on Linux

Problem	On Linux systems running in one of the UTF-8 locales (en_US.UTF-8), text may be missing from the Teamcenter lifecycle visualization user interface. For example, text may be missing from the assembly tree or the File Open dialog box. On systems with this issue, when you start the application, it may display the following error message:
---------	---

```
Font Creation Failed
```

Also, the X11 log file (**/var/log/Xorg.0.log**) may contain error messages such as the following:

```
FreeType:  couldn't find encoding 'iso8859-15' for '/.../generic.ttf'.
```

This is a result of some Linux distributions failing to generate the **encodings.dir** file during installation. X11 requires the **encodings.dir** file to load fonts in UTF-8 locales.

Workaround	<ol style="list-style-type: none"> 1. Ensure that all X11 Unicode font packages are installed. 2. Navigate to the X11 fonts/encodings/ directory. On Red Hat Enterprise Linux 6, this directory is located at /usr/share/X11/fonts/encodings, but other distributions may put the encodings folder in a different location. 3. If the encodings.dir file does not exist in this location, generate the file using the mkfontdir command. On Red Hat 6, type the following at the command prompt:
------------	---

```
cd /usr/share/X11/fonts/encodings
as root mkfontdir -e /usr/share/X11/fonts/encodings \
-e /usr/share/X11/fonts/encodings/large
```

Note

You must run the **mkfontdir** command from the directory containing the encodings, and it should have a separate **-e** flag for each subdirectory that also contains encodings, such as the **encodings/large/** subdirectory on RedHat 6.

4. If the **encodings.dir** file exists and the problem persists, check to make sure that it includes encodings for each of the classes in the **XLC_LOCALE**

file for the locale (in `/usr/share/X11/locale/en_US.UTF-8/` on Red Hat 6, for example), or regenerate the `encodings.dir` file using the above directions.

Visualization files are not associated with the viewer on OS X

Problem When you install Teamcenter lifecycle visualization on a Mac, the installer does not automatically associate supported file types with the viewer. You must manually associate supported file types with the viewer to do the following:

- Double-click a supported file type to open it in the viewer.
- Send visualization files from the Teamcenter Thin Client or Community directly into the viewer.

Workaround In the Visualization application installation directory, there is a simple native Mac OS X application called `ViewerLauncher.app` which you can associate with Lifecycle Visualization file types.

When you double-click a visualization file type that has been associated with `ViewerLauncher.app`, the application launches one of the following scripts:

- `bin/vvbaselaunch`
- `bin/vvstdlaunch`
- `bin/vvprolaunch`

By default, the script launched is `vvprolaunch`, which corresponds to the Professional license level. You can modify the following file to specify a different license level:

`ViewerLauncher.app/Contents/Resources/English.lproj/Settings.txt`

Note

If you are using Safari to send visualization files from the Teamcenter Thin Client or Community directly into the viewer, you must also configure the browser to treat `.vvi` files as safe files.

VVI files are not sent directly into the viewer on OS X

Problem When using the Teamcenter Thin Client or Community in Safari, `.vvi` files are not sent directly into the viewer. Instead, the `.vvi` is saved to your local file system, and you must manually open it in the viewer.

Workaround You must configure Safari to treat .vvi files as safe files for visualization data to open directly in the viewer. This behavior is controlled with a plist file named “com.apple.DownloadAssessment.plist”. This file is packaged with the ViewerLauncher.app. Copy it to this location:

`$(Home)/Library/Preferences`

The key named “LSRiskCategorySafe” defines file types that are treated as safe and automatically opened in the viewer. The subkey “LSRiskCategoryContentTypes” defines an array of safe file extensions called “LSRiskCategoryExtensions”, which must contain a string named “VVI”. Note that the sample .plist file included with the installation is already configured to treat .vvi files as safe.

Teamcenter Visualization is not installed to the Applications folder on OS X

Problem On Mac OS X, the Teamcenter lifecycle visualization application and related files are not installed to the Applications folder.

Workaround If you want ViewerLauncher.app to be in the Applications folder, you must do the following:

1. From the command prompt, move all of the visualization files and folders at the same level as ViewerLauncher.app into the ViewerLauncher.app application bundle (Mac .app files include a hidden folder structure, with the top-level directory having a name that ends with the .app extension).
2. Move ViewerLauncher.app to the Applications folder.

Product views display parts in incorrect positions

Problem Parts may appear in incorrect positions when product views authored in the Lifecycle Viewer or the stand-alone application viewer are restored in certain Teamcenter embedded viewers. This problem occurs when the motion system records part transformations on subassembly nodes, and the transformations are subsequently captured by the product view. These assembly-level transformations generated by the motion system are not applied correctly when the product view is restored in Structure Manager, Multi-Structure Manager, and Manufacturing Process Planner.

Workaround You can avoid this limitation by keeping 3D part transformations at the part level when working with motion in the Lifecycle Viewer or the stand-alone application viewer. Rather than transforming an entire assembly or subassembly, expand the structure and select all of the individual parts and move them instead.

The help does not display properly in Internet Explorer 9

Problem When the Internet Explorer 9 Compatibility View setting is turned off, the help does not display properly.

- Workaround To view the help in Internet Explorer 9, you must turn on Compatibility View. In IE 9, do the following:
1. Choose **Tools**→**Compatibility View Settings**.
 2. In the **Compatibility View Settings** dialog box, select the **Display all websites in Compatibility View** check box.

An ActiveX warning is displayed each time the help is started

- Problem When you launch the help, an ActiveX warning is displayed.
- Workaround To get rid of the ActiveX warning, do the following:
1. Choose **Tools**→**Internet Options**→**Advanced**.
 2. In the **Settings** area, scroll down to the **Security** section, and select the **Allow active content to run in files on My Computer** check box.
 3. Click **OK**.
 4. Close and reopen the browser.

Rendering artifacts during moving frame navigation

- Problem Lifecycle Visualization includes new technology to greatly increase the interactivity of moving frame navigation for medium and large assemblies on multi-processor workstations. This feature is automatically disabled on single-CPU machines.

When you navigate rapidly about the 3D model, objects near the edge of the Viewing window may be delayed for a few frames before appearing. This is a normal side-effect of the performance enhancement. The severity of the effect is proportional to the size of the assembly being viewed, the number of polygons being rendered, and the speed of the graphics card.

- Workaround To turn this feature off, you must set the environment variable **TCVIS_DISABLE_ASYNCSTRATEGY** to **True**. However, you should disable this feature only if your machine freezes or crashes.

Issue with nVidia G-Sync cards

- Problem If you have an nVidia G-Sync option card, unexpected errors may occur when using it in a PC cluster environment. Graphics adapters that support the nVidia G-Sync option card include the nVidia Quadro FX graphics solutions.

- Workaround** The problem has been fixed in nVidia driver version 197.28 and above. To resolve the issue, update your driver.
- If you are using an older driver, you can set up the following system environment variable to disable the G-Sync effect in Lifecycle Visualization:
- TCVIS_CLUSTER_NOGSYNC=True**

Visibility filter and Use Off-Screen Rendering option

- Problem** When you turn off **Use Off-Screen Rendering**, the 3D graphics window must be completely clear of other windows. If any windows are covering the 3D graphics window in any way, the visibility check does not work.
- Workaround** It is recommended that you do not turn off **Off-Screen Rendering**.

Installing the Windows cluster service

- Problem** A cluster is a Windows-based system that contains multiple workstations. Before you can use clusters, you must install an additional Windows service program (`TeamcenterVisClusterLaunch.exe`) on the client nodes.
- Workaround** Install the Windows cluster service. For information on installing the service, see *Installing and uninstalling the Windows cluster service* in the stand-alone Lifecycle Visualization *Installation Guide*.

Functionality not supported in PC clusters

- Problem** Some functionality where new geometry or other content is generated dynamically during the course of the session will not work with PC clusters, including, but not limited to the following:
- Part edit
 - Environment map image captures for advanced materials
 - Jack
 - Variation Analysis
 - Visualization Illustration
 - 3D compare
 - Surface analysis
 - Layer filters
 - Animation file loading

Workaround None

Attempting to interoperate an assembly to a new NX manager fails

Problem Interoperating an assembly to a new NX manager from Lifecycle Visualization fails if the assembly was originally sent to Lifecycle Visualization from Teamcenter.

Workaround Start NX from Teamcenter before interoperating an assembly from Lifecycle Visualization. From the **File**→**Interoperate** menu in Lifecycle Visualization, choose the running NX manager instead of a new NX manager.

Assembly names are different when sent from NX and Teamcenter

Problem If an assembly is sent to Lifecycle Visualization directly from Teamcenter, the name in the assembly tree view has the Item ID, ItemRev, and ItemName. The Item ID, ItemRev, and ItemName are not present if the assembly is sent from NX.

Workaround A solution where the Item ID, ItemRev, and ItemName are sent to Lifecycle Visualization as user data in the PLM XML is in NX 5.0.2 and later releases. This solution allows a Lifecycle Visualization user to add these as columns in the Assembly Tree. A longer term solution also is under investigation.

Session files lose association to animation files

Problem On Linux, you will encounter issues when you have a session file that references an animation primary document. When a 3D view from the session file is associated with the animation, that relationship should be preserved and re-established when you open the session. However, on Linux the relationship between the 3D view and the animation does not get re-established. Therefore, if you run the animation, it attempts to create a new 3D view instead of using the one that is present as part of the session.

Workaround Perform the following steps:

1. Load the session (this loads the 3D view and the animation document).
2. Select the 3D view to be the animation target.
3. Select a part in the Viewing window.
4. Choose **Animation**→**Associate 3D View with Animation**.

Cannot save PLM XML motion file formats to Teamcenter

Problem When you try to save motion data to Teamcenter using the PLM XML Motion Frame or PLM XML Motion Keyframe file formats, an error message is displayed.

Workaround You must use the VFM file format when saving motion data to Teamcenter. The PLM XML motion file formats are not supported.

Support for localized user interface in Visualization Illustration

Problem	The language shown on the user interface may be inconsistent when using Visualization Illustration.
Workaround	<p>To provide a consistent user interface with respect to the user interface language presented by the viewer and the user interface language presented by the Visio Drawing Control, you must install one of the following:</p> <ul style="list-style-type: none"> • An English Visio 2010, 2013, or 2016 product install and a MUI pack supporting the language of choice • A localized Visio2010, 2013, or 2016 product install for the language of choice <p>Only when the Microsoft Office 2010 or Visio 2013 Language Settings tool has the user interface language set to the same language as specified for the default system locale will the user interface language be consistent throughout the entire Visualization Illustration application.</p>

In non-English versions of Visualization Illustration, opening an SVG file containing Assets displays a blank screen.

Problem	Opening an SVG file containing Assets displays a blank screen when Windows is configured to use a comma as the decimal symbol.
Workaround	<p>Configure Windows to use a period as the decimal symbol.</p> <ol style="list-style-type: none"> 1. Open Windows Control Panel. 2. Choose Region and Language. 3. In the Region and Language dialog box, on the Formats tab, click Additional setting. 4. In the Customize Format dialog box, on the Numbers tab, change Decimal symbol from "," to ".".

Visualization Illustration asset capturing may stop working after uninstalling Lifecycle Visualization

Problem	After uninstalling Lifecycle Visualization when a previous version of Lifecycle Visualization is still installed, you may need to repair the previous installation to restore the proper functioning of the previous version of Asset Capture. This problem results in the following error message: <code>Failed to create the session data container.</code>
---------	---

- Workaround
1. From the **Common Files** installation folder (for example, **C:\Program Files\Common Files\Siemens Shared\TcVis\9.1**), remove the module **VP3DGeomAssetData.dll**.
 2. Run the repair option of the installation of the earlier version of Lifecycle Visualization.

Visualization Illustration enablement

Problem Visualization Illustration users may notice that even though they have installed Visualization Illustration, they are not seeing certain functionality exposed. In particular, the following:

- The Asset Clipboard does not appear when a 3D view is opened.
- You cannot capture a 3D geometry asset.

Workaround The first and most obvious reason for this may be a lack of a new Visualization Illustration license.

The second reason for this may be the absence of a Visio 2010, 2013, or 2016 installation. If either of these is not available, Visualization Illustration and all related functionality will be disabled.

Microsoft installer launches on start of Visio

Problem The Lifecycle Visualization installer does not associate the Visio .vsd file type with Visio. As a result, double-clicking a .vsd file causes the Visio application to launch and load the document. However, because Visualization Illustration Technical Illustrations are built using Visio as a drawing engine, Technical Illustrations are Visio documents with a .vsd extension. As a result, there are some users that elect to associate the Viewer with the .vsd file type. By doing so, double-clicking a .vsd file causes the Viewer to launch and load the document. Regardless of which application is associated with the .vsd file type, .vsd files can always be opened in the Viewer through **File → Open**.

If Microsoft detects during the startup of Visio that the .vsd file is not associated with the Visio application, the Microsoft Installer runs as a means to automatically repair what Microsoft views as a broken association. A description of this behavior can be found at <http://support.microsoft.com/?id=290997>. At the bottom of this article is a link that describes how to disable this behavior. However, this approach completely disables the Microsoft Installer.

Workaround A workaround for this problem is to not associate the .vsd file type with the Viewer. Rather than double-clicking the .vsd file type to launch the application, right-click the .vsd file and use the Microsoft Explorer **Open With** shortcut menu to open the file.

Variation Analysis issues

Problem	<p>The following issues apply to Variation Analysis.</p> <ul style="list-style-type: none"> • When extracting NX PMI data from a JT file, slot and tab patterns are not supported. • When extracting NX PMI data from a JT file, the following tolerances do not flow down to Variation Analysis. <ul style="list-style-type: none"> o PMI shown in multiple NX views are duplicated in JT PMI and subsequently in the Variation Analysis. o Unilateral and unequal bilateral profile tolerances indicated by the  modifier are not recognized. • Reference dimension and angular plus-minus tolerances are not recognized. • The flowdown of linear plus-minus tolerances (directed dimensions in NX PMI) require NX 10 or later. • Rename/Remap does not work when the object being moved is the assembly node that is being duplicated. • FCFs (Feature Control Frames) show a non-existing datum reference when a feature is linked to the tolerance library.
Workaround	None

Chapter 9: Supported file formats

Teamcenter lifecycle visualization supports the following file formats:

- 2D file formats
- 3D file formats
- ECAD file formats
- 2D/3D file formats
- Lifecycle Visualization authored file formats
- Motion file formats supported for conversion to VFM
- Visualization Illustration supported file formats
- Lifecycle Visualization file formats
- Supported versions of the JT file format
- Supported versions of other Siemens PLM Software file formats

Note

- Some file types may need an optional translator. Consult your system administrator for assistance.
- To view, convert, and print Office documents, you must have Microsoft Office installed.
- To avoid seeing construction geometry in Lifecycle Visualization, clean up your construction geometry in NX before opening the file in the viewer.
- Non-geometry data, such as PMI, is not supported.
- Wireframe data is not supported.
- 2D .prt files must contain embedded CGM data.

2D file formats

You can open the following 2D file formats:

Abbreviation	Extension	Description	Type	Prerequisites
Raster and Document				

Abbreviation	Extension	Description	Type	Prerequisites
BMP	.bmp	Microsoft Windows or OS/2 bitmap file	Raster	None
C4	.C4	JEDMICS C4 tiled raster format	Raster	None
CG4	.CG4	CALS Group IV format	Raster	None
DOC	.doc	Microsoft Word	Document	Install MS Word
DOC	.docx	Microsoft Word	Document	Install MS Word
DFT (Windows only)	.dft	Solid Edge draft files Note For details on supported versions, see <i>Supported versions of other Siemens PLM Software file formats</i> .	Raster	None
EMF (Windows only)	.emf	Microsoft Enhanced Metafile	Raster	None
GIF	.gif	CompuServe color raster format	Raster	None
HDR	.hdr	High Dynamic Range images Note High Dynamic Range (HDR) images are supported for 3D light maps only. Light maps can use OpenEXR or Radiance RGBE Encoding HDR images.	Raster	None
JPEG	.deft, .jpeg, .jiff, .jpe, .jpg	JPEG file	Raster	None

Abbreviation	Extension	Description	Type	Prerequisites
JPEG 2000	.j2k, .jp2, .jpc	JPEG 2000 file Note Using Teamcenter Visualization 2005 and later, you can display and save JPEG 2000 files.	Raster	None
MLR	.mlr, .mil, .milr, .CAL	MIL-R-28002 Type 1 Raster	Raster	None
MPP	.mpp	Microsoft Project	Document	Install MS Project
MPC	.mpc	Multi-page CALS file	Raster	None
PBM	.pbm	Portable BitMap image file Note The application only supports viewing this file type.	Raster	None
PCX	.pcx	Windows Paintbrush image file	Raster	None
PGM	.pgm	Portable GrayMap image file Note The application only supports viewing this file type.	Raster	None
PNG	.png	PNG file format	Raster	None
PNM	.pnm	Portable AnyMap image file Note The application only supports viewing this file type.	Raster	None

Abbreviation	Extension	Description	Type	Prerequisites
PPM	.ppm	Portable PixMap image file Note The application only supports viewing this file type.	Raster	None
PPT	.ppt	Windows PowerPoint	Document	Install MS PowerPoint
PPT	.pptx	Windows PowerPoint	Document	Install MS PowerPoint
PS	.ps, .eps	PostScript (Level 1, Level 2, EPS)	Raster	Install Ghostscript
RAS	.ras, .sun	Bi-level Sun raster	Raster	None
RGB	.rgb, .rgba, .sgi, .bw	SGI RGB file	Raster	None
RVF	.rvf	Raster Viewing Format	Raster	None
TG4	.tg4	CCITT Group 4 Type II tiled image format	Raster	None
TGA	.tga	Truevision Targa	Raster	None
TIFF	.tif, .tiff	Tagged Image File Format	Raster	None
TLC	.tlc	TLC file format	Raster	None
TRIFF	.fsx, .ovx., .fs, .ov	Monochrome, single and multi-page tiled raster file format	Raster	None
WBMP	.wbmp	Wireless Bitmap	Raster	None
WMF (Windows only)	.wmf	Windows Metafile	Raster	None
XLS	.xls, .cvs	Microsoft Excel	Document	Install MS Excel
XLS	.xlsx, .cvs	Microsoft Excel	Document	Install MS Excel
Vector				
907	.906, .907, .CAL	Calcomp 906, 907	Vector	None

Abbreviation	Extension	Description	Type	Prerequisites
CGM	.cgm	Binary Computer Graphics Metafile MIL-D-28003 ANSI X3.122 Note Teamcenter Visualization 2005 and later supports CGM Version 4, while maintaining support for CGM Versions 1 through 3. Teamcenter Visualization 2005 also supports WebCGM files.	Vector	None
DGN (Windows only)	.dgn	Microstation DGN file format (available on Windows)	Vector	None
DWF	.dwf	Autodesk Drawing Web Format files Note The application supports DWF version 6 formatted files, including the new .w2d file extension. Embedded raster data is supported only on Windows.	Vector	None

Abbreviation	Extension	Description	Type	Prerequisites
DWG	.dwg	AutoCAD Internal file format <div data-bbox="721 342 1000 680" style="background-color: #f0f0f0; padding: 5px;"> <p>Note</p> <p>The following types of embedded raster data are supported: BMP, JPG, GIF, MLR, TIFF, and PNG.</p> </div>	Vector	None
GERBER	.gbr, .gbx, .gvl	Gerber RS274D and RS274X formats <div data-bbox="721 785 1000 1123" style="background-color: #f0f0f0; padding: 5px;"> <p>Note</p> <p>Use .gvl files to open a list of Gerber files as one document with layers for each file in the list.</p> </div>	Vector	None
HPGL	.hgl, .hpg, .hppl, .hp2, .plt	HP Graphics Language (HPGL and HPGL/2) <div data-bbox="721 1232 1000 1738" style="background-color: #f0f0f0; padding: 5px;"> <p>Note</p> <p>The application recognizes additional files as HPGL if you set the EAI_HPGL_EXTENSIONS environment variable. The setting should be a comma separated list of file extensions.</p> </div> <div data-bbox="721 1780 1000 1913" style="background-color: #f0f0f0; padding: 5px; margin-top: 10px;"> <p>Example</p> <p>"hpgl2,hpgl3"</p> </div>	Vector	None

Abbreviation	Extension	Description	Type	Prerequisites
IDW (Windows only)	.idw	Autodesk Inventor drawing file format	Vector	To work with the Autodesk Inventor files, you must have Autodesk Inventor, Autodesk Inventor View, or Design Tracking. Autodesk Inventor View and Design Tracking are freely distributed and available from Autodesk. Autodesk Inventor .idw files prior to version 5.3 are not supported.
IGES	.igs, .iges	Initial Graphics Exchange Input File Specification, MIL-D-28000	Vector	None
MDL	.mdl	Model file	Vector	None
W2D	.w2d	Autodesk toolkit	Vector	None
Miscellaneous				
AI	.ai	Adobe Illustrator	Vector or Raster	For Linux, and Mac, install Ghostscript
MDS	.mds	MetaData Stamp	Vector or Raster	None
PDF	.pdf	Portable Document Format Note On Windows, you can directly create and work with PDF documents.	Raster	For Linux, and Mac, install Ghostscript
TXT	.txt	ASCII text file format	Document	None
WebCGM	.cgm	CGM file management through Web browsers, hyperlinks, and other supported WebCGM file features.	None	None

Abbreviation	Extension	Description	Type	Prerequisites
ZIP	.zip	ZIP files containing one or more files of a supported 2D format <div data-bbox="721 411 1000 989" style="background-color: #f0f0f0; padding: 10px;"> <p>Note</p> <p>The 2D files contained within the ZIP file are displayed in a single multipage 2D image window. You can navigate through the pages (files) using any of the available 2D multipage navigation options.</p> </div>	None	None
7-Zip	.7z	7-Zip files containing one or more files of a supported 2D format <div data-bbox="721 1129 1000 1747" style="background-color: #f0f0f0; padding: 10px;"> <p>Note</p> <p>The 2D files contained within the 7-Zip file are displayed in a single multipage 2D image window. You can navigate through the pages (files) using any of the available 2D multipage navigation options.</p> </div>		

3D file formats

You can open the following 3D file formats:

Abbreviation	Extension	Description
ASM (Windows only)	.asm	<p>Assembly file for Solid Edge that can reference .par, .psm, .pwd, and other .asm files.</p> <p>Note</p> <p>For details on supported versions, see <i>Supported versions of other Siemens PLM Software file formats</i>.</p>
BLK	.blk	<p>NASTRAN bulk format</p> <p>Note</p> <p>To work with IGES files, the IGES optional translator must be properly installed and licensed.</p>
IGES 5.3	.igs, .iges	<p>Initial Graphics Exchange Input File Specification, MIL-D-28000</p> <p>Note</p> <p>To work with IGES files, the IGES optional translator must be properly installed and licensed.</p>
JT	.jt	<p>DirectModel file format</p>
PAR (Windows only)	.par	<p>Solid Edge single part file</p> <p>Note</p> <p>For details on supported versions, see <i>Supported versions of other Siemens PLM Software file formats</i>.</p>
PLM XML	.plmxml	<p>XML format that supports product view and product structure data</p>
PSM (Windows only)	.psm	<p>Solid Edge sheet metal file</p> <p>Note</p> <p>For details on supported versions, see <i>Supported versions of other Siemens PLM Software file formats</i>.</p>
PWD (Windows only)	.pwd	<p>Solid Edge weldment file</p> <p>Note</p> <p>For details on supported versions, see <i>Supported versions of other Siemens PLM Software file formats</i>.</p>

Abbreviation	Extension	Description
RES	.res	ADAMS results file format Note <ul style="list-style-type: none"> Lifecycle Visualization supports ADAMS RES 2010 and 2013 files. The ADAMS conversion feature, which converts RES files to the VFM motion file format, requires the Professional or Mockup product configuration, as well as an additional license. It is supported on Windows only.
STEP AP203, 214	.stp	Standard for Exchange of Product Note To work with STEP files, the STEP optional translator must be properly installed and licensed.
VRML	.wrl, .vrmf	Virtual Reality Markup Language Note <ul style="list-style-type: none"> VRML support is for geometry and appearance attributes only. You can export 3D models in only the VRML 1.0 format. Both VRML 1.0 and 2.0 files can be imported.
XMO	.xmo	XML-based motion file format
XT	.x_t, .x_b, .xmt_txt, .xmt_bin	Parasolid XT File Note For details on supported versions, see <i>Supported versions of other Siemens PLM Software file formats</i> .

Note

The CADDs format is no longer supported. You can use the CADDs to JT translator to translate single CADDs files or to perform automated batch translations of multiple CADDs files.

ECAD file formats

You can open the following file formats in ECAD:

Abbreviation	Extension	Description
BCZ	.bcz	Teamcenter Briefcase
XFATF	.xfatf	PCB file
XSCH	.xsch	Schematic File
XRUL	.xrul	Contains the ECAD DFx rules.
XRES	.res	Contains the ECAD DFx results.
CGM	.cgm	ECAD Markup layer.

2D/3D file formats

You can open the following 2D/3D file formats:

Abbreviation	Extension	Description
DXF	.dxf	<p>AutoCAD drawing interchange format</p> <p>Note</p> <ul style="list-style-type: none"> To work with 3D DXF files, the DXF optional translator must be properly installed and licensed. The following types of embedded raster data are supported: BMP, JPG, GIF, MLR, TIFF, and PNG. Solids are not supported.
DWG	.dwg	<p>AutoCAD Internal file format</p> <p>Note</p> <p>The following types of embedded raster data are supported: BMP, JPG, GIF, MLR, TIFF, and PNG.</p>
IGES	.igs, .iges	<p>Initial Graphics Exchange Input File Specification, MIL-D-28000</p> <p>Note</p> <p>To work with IGES files, the IGES optional translator must be properly installed and licensed.</p>

Abbreviation	Extension	Description
PRT	.prt	NX part file <div style="background-color: #f0f0f0; padding: 5px;"> <p>Note</p> <p>Lifecycle Visualization supports direct viewing of NX .prt files. For details on supported versions, see <i>Supported versions of other Siemens PLM Software file formats</i>.</p> </div>

Lifecycle Visualization authored file formats

You can save data as the following file formats:

Abbreviation	Extension	Description
907	.907	Calcomp 907
951	.951	Calcomp 951
AVI	.avi	Video (Windows)
BCZ	.bcz	Teamcenter Briefcase
BMP	.bmp	Microsoft Windows or OS/2 bitmap file
CGM	.cgm	2D Markup layer or ECAD
CSV	.csv	Clearance DB report
DBC	.dbc	Clearance DB Database Connection
ENV	.edv	Jack Environment (session)
FIG	.fig	Jack Figure (session)
GIF	.gif	Graphics Interchange Format <div style="background-color: #f0f0f0; padding: 5px;"> <p>Note</p> <p>You must have a license to work with Visualization Illustration.</p> </div>
HPGL	.hpg	HP Graphics Language (HPGL and HPGL/2)
J2K	.j2k, .jp2, .jpc	JPEG 2000
JPEG	.jpg	JPEG file <div style="background-color: #f0f0f0; padding: 5px;"> <p>Note</p> <p>You must have a license to work with Visualization Illustration.</p> </div>
JT	.jt	DirectModel Format
MLR	.mlr, .mil, .milr	MIL-R-28002 Type 1 Raster
MPEG	.mpg	Video (Mac and Linux)
P-SURF	.pss	Jack P-Surface (Part)

Abbreviation	Extension	Description
PCX	.pcx	Windows Paintbrush image file
PDO	.pdo	Process documents
PFC	.pfc	Vehicle Integrated Process Flow Charts
PLMXML	.plmxml	Product Structure
PNG	.png	PNG file format Note You must have a license to work with Visualization Illustration.
PS	.ps	PostScript (EPS)
PVL	.pvl	2D Image View List
ROBFACE	.asy	Robface format
RVF	.rvf	Raster Viewing Format
SCD	.scd	Sensor Configuration Definition
STEP AP203	.stp	Standard for Exchange of Product Note To work with STEP files, the STEP optional translator must be properly installed and licensed.
SVG	.svg	Scalable Vector Graphics Note You must have a license to work with Visualization Illustration.
TIFF	.tif	Tagged Image File Format
TXT	.txt	3D Measurement Report, 3D PMI Point Report, Clearance Results
V3G	.v3g	3D Geometry Asset
VAN	.van	Animation
VCD	.vcd	Video Configuration Definition
VF	.vf	Work sessions
VFM	.vfm	Motion
VFZ	.vfz	Work Session Package

Abbreviation	Extension	Description
VML	.vml	Vector Markup Language Note You must have a license to work with Visualization Illustration.
VPL	.vpl	3D markup layers
VRML	.wrl	Virtual Reality Markup Language Note <ul style="list-style-type: none"> VRML only supports geometry. You can export 3D models in only the VRML 1.0 format. Both VRML 1.0 and 2.0 files can be imported.
VSD	.vsd	Technical Illustration
VTP	.vtp	Technical Portfolio
VVS	.vvs	Viewer State Script
XML	.xml	Attribute Color, Search Trace Results file, SPC measurement data file, XML point import and export file, exported Flowchart file, ECAD markup metadata file
XRUL	.xrul	Contains the ECAD DFX rules.
XRES	.xres	Contains the ECAD DFX results.
ZN	.zn	Clearance Zone

Motion file formats supported for conversion to VFM

You can convert the following file types to the VFM motion file format:

Note

VFM files saved in Lifecycle Visualization 11.6/12.1 are not compatible with earlier releases of Lifecycle Visualization.

Abbreviation	Extension	Description
XMO	.xmo	Motion

Abbreviation	Extension	Description
RES	.res	ADAMS Results Files <div style="border: 1px solid gray; padding: 5px; margin-top: 10px;"> <p>Note</p> <ul style="list-style-type: none"> • Lifecycle Visualization supports ADAMS RES 2010 and 2013 files. • The ADAMS conversion feature, which converts RES files to the VFM motion file format, requires the Professional or Mockup product configuration, as well as an additional license. It is supported on Windows only. </div>

Visualization Illustration supported file formats

Note

You must have a license to work with Visualization Illustration.

You can work with the following file formats in Visualization Illustration:

Abbreviation	Extension	Description
BMP, DIB	.bmp, .dib	Windows Bitmap
EMZ	.emz	Compressed Enhanced Metafile
EMF (Windows only)	.emf	Enhanced Metafile
GIF	.gif	Graphics Interchange Format
JPEG	.jpg	JPEG Interchange Format
PNG	.png	Portable Network Graphics
SVG, SVGZ	.svg, .svgz	Scalable Vector Graphics
TIF, TIFF	.tif, .tiff	Tag Image File Format
VML	.vml	Vector Markup Language

Lifecycle Visualization file formats

Lifecycle Visualization features utilize the following file formats:

Abbreviation	Extension	Description
CSV	.csv	ClearanceDB report
DBC	.dbc	ClearanceDB Database Connection file
ENV	.edv	Jack Environment (session)
FIG	.fig	Jack Figure (session)

Abbreviation	Extension	Description
eXT	.ext	ASCII XML format developed by Parasolid Note The application no longer saves data in the .eXT format. You can read .eXT files, but you can save product view data only in the .plmxml format.
JT	.jt	DirectModel Format
PDO	.pdo	Process documents
PFC	.pfc	Vehicle Integrated Process Flow Charts
P-SURF	.pss	Jack P-Surface (Part)
PLMXML	.plmxml	Product Structure
VAN	.van	Animation
VBK	.vbk	Illustration Book
VF	.vf	Work sessions
VFM	.vfm	Motion
VFP	.vfp	Autofile Locate preferences file.
VFZ	.vfz	Work Session Package
VPL	.vpl	3D markup layers
XML	.xml	Attribute Color, Search Trace Results file, SPC measurement data file, XML point import and export file, exported Flowchart file
XMO	.xmo	Motion
ZN	.zn	Clearance Zone

Supported versions of the JT file format

You can open and, depending upon your licensing configuration, save the following versions of the JT file format:

Teamcenter lifecycle visualization version	JT version	JT and XT B-Rep support	ULP support
5.x	8.1 and earlier	Yes	No
6.x	8.1 and earlier	Yes	No
2007 (PLM1)	8.3 and earlier	Yes	Preliminary
2007.1	9.1 and earlier	Yes	Yes
2007.1.1	9.2 and earlier	Yes	Yes
8.0	9.3 and earlier	Yes	Yes
8.1	9.4 and earlier	Yes	Yes
8.2	9.5 and earlier	Yes	Yes
8.3	9.5 and earlier	Yes	Yes
9.x	9.5 and earlier	Yes	Yes
10	9.5 and earlier	Yes	Yes

Teamcenter lifecycle visualization version	JT version	JT and XT B-Rep support	ULP support
10.1	10.0 and earlier	Yes	Yes
11.1	10.0 and earlier	Yes	Yes
11.2	10.2 and earlier	Yes	Yes
11.3	10.2 and earlier	Yes	Yes
11.4	10.2 and earlier	Yes	Yes
11.5	10.2 and earlier	Yes	Yes
11.6	10.2 and earlier	Yes	Yes

Supported versions of other Siemens PLM Software file formats

For information about the supported versions of other Siemens PLM Software file formats, see the Interoperability matrix on the Hardware and Software Certifications page on GTAC: https://www.plm.automation.siemens.com/en_us/support/gtac/certifications.shtml.

Chapter 10: Global Technical Access Center (GTAC)

To report any serious problems about Lifecycle Visualization, please contact the Global Technical Access Center.

Phone:

- USA and Canada: (800) 955-0000 or (714) 952-5444
- Outside the United States and Canada: Contact your local support office.

Website:

You can also log and view any existing resolutions for incident reports on the Web at <http://www.siemens.com/gtac>.

Siemens Industry Software

Headquarters

Granite Park One
5800 Granite Parkway
Suite 600
Plano, TX 75024
USA
+1 972 987 3000

Americas

Granite Park One
5800 Granite Parkway
Suite 600
Plano, TX 75024
USA
+1 314 264 8499

Europe

Stephenson House
Sir William Siemens Square
Frimley, Camberley
Surrey, GU16 8QD
+44 (0) 1276 413200

Asia-Pacific

Suites 4301-4302, 43/F
AIA Kowloon Tower, Landmark East
100 How Ming Street
Kwun Tong, Kowloon
Hong Kong
+852 2230 3308

About Siemens PLM Software

Siemens PLM Software, a business unit of the Siemens Industry Automation Division, is a leading global provider of product lifecycle management (PLM) software and services with 7 million licensed seats and 71,000 customers worldwide. Headquartered in Plano, Texas, Siemens PLM Software works collaboratively with companies to deliver open solutions that help them turn more ideas into successful products. For more information on Siemens PLM Software products and services, visit www.siemens.com/plm.

© 2018 Siemens Product Lifecycle Management Software Inc. Siemens and the Siemens logo are registered trademarks of Siemens AG. D-Cubed, Femap, Geolus, GO PLM, I-deas, Insight, JT, NX, Parasolid, Solid Edge, Teamcenter, Tecnomatix and Velocity Series are trademarks or registered trademarks of Siemens Product Lifecycle Management Software Inc. or its subsidiaries in the United States and in other countries. All other trademarks, registered trademarks or service marks belong to their respective holders.